

MARUZEN

HYDRAULIC HANDHELD BREAKER

MODEL BH20EV

OPERATING MANUAL



CAUTION

FOR THE SAFETY PURPOSE, PLEASE READ THIS MANUAL THOROUGHLY BEFORE ATTEMPTING TO USE THIS BREAKER. ANY FALES OPERATING PROCEDURES WILL CAUSE DAMAGES TO THE MACHINE. ALWAYS KEEP THIS MANUAL TO AN EASILY ACCESSABLE PLACE.



MARUZEN KOGYO CO., LTD.

(Nov 20, 2015)

FOREWORD

This manual is an important part of your equipment. It provides rules and guidelines which will help you use this machine safely and effectively. You **MUST** familiarize yourself with the functions and operations by reading the manual thoroughly before you begin using this machine. For your safety, it is especially important that you read and observe all precautions in this manual and labels on the machine. The precautions **MUST** be followed strictly at all times when performing operation and maintenance. * Fail to follow the guidelines and safety alerts in the manuals and on the machine, or use this machine in alternative ways from the manuals may result in system failure or serious personal injury.

Keep this manual with the equipment or in an easily accessible place in all times for future reference. Make sure all personnel involved in working on this machine can consult it periodically. In case this manual should be lost or damaged, immediately contact us or your dealer to purchase a new copy.

We recommend you always use Maruzen genuine components and parts. Replacing components and parts from other sources may cause damages to this machine and endanger operators.

MARUZEN KOGYO CO., LTD.
155-8 NAGABUSE, MISHIMA-SHI,
SHIZUOKA-KEN, 411-0824, JAPAN

CONTENTS

Safety Information.....	4 ~ 7
Safety Alert Classifications.....	4
Safety Alerts	5 ~ 7
Introductions.....	8
How To Adjust the Hammering Power.....	8
Specifications & Descriptions.....	9
Precaution Labels and Positions.....	10
Inspection before Each Operation.....	11
Guidelines	12 ~ 13
Operation.....	14 ~ 15
Daily Check Out.....	16
Periodically Inspection	16
Available Tools	16
Troubleshooting.....	17~ 18
Exploded View	19
Parts List.....	20 ~ 21

SAFETY INFORMATION

To enable you to use this machine safely, safety precautions and labels are given in this manual and affixed to the machine to give explanations of situations involving potential hazards and of the methods of avoiding such situations.

SAFETY ALERT CLASSIFICATIONS

The following safety alert symbols are used to inform you that there is a potential hazardous situation that may lead to personal injury or damage.

In this manual and on machines labels, the following safety alert symbol are used to express the potential level of hazard.



Indicates an imminently hazardous situation which, if not avoided, could result in death or serious injury.



Indicates a potentially hazardous situation which, if not avoided, could result in death or serious injury.

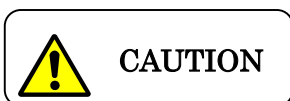

Indicates a potentially hazardous situation which, if not avoided, could result in minor or moderate injury.

**** Safety alert symbols are to emphasize all operation which, if not strictly followed, could result in a life-threatening situation, bodily injury or damage to equipment.**

SAFETY ALERTS

DO NOT OPERATE THE MACHINE UNLESS THE FOLLOWING SAFETY INSTRUCTIONS HAVE BEEN THOROUGHLY READ AND UNDERSTOOD!



WARNING

Before operating the equipment, be sure to wear personal protective equipments such as follows:

1. **Helmet**
2. **Protective goggles**
3. **Protective boots**
4. **Safety gloves**
5. **Hearing Protection**



WARNING

Do not operate the equipment if you are or if your

1. **taking medication, feeling drowsy, feeling unwell or feeling tired.**
 2. **under the influence of drugs or alcohol.**
 3. **hands, feet, lower back or other parts of your body hurt or being injured.**
- * Failure to observe this precaution can result serious injury or even death.**

**CAUTION**

Do not touch the machine with your bare hands

1. The oil tank may become hot under continuous running.
Do not touch the equipment with your bare hands.

2. Tools may become hot under continuous use, make sure to wear gloves before any contact with the tools.

* Failure to observe this precaution can result getting burned

**CAUTION**

When lending someone the equipment

Make sure the safety instructions have been thoroughly read and fully understood by the person who is going to use the equipment.

**WARNING**

Avoid Blank Hammering

Operating the equipment horizontally may cause the chisel's sudden flying out.

Excessive blank hammering may be considered equipment abuse and may cause equipment damage.

Failure to observe this precaution can result damage to the breaker.



WARNING

Never operate the breaker when bystanders are in the work area

1. Do not operate the breaker if any people are within the area where flying debris or movement of the breaker may injure them.
2. For preventing flying debris, make sure protection fences are being set up.

Failure to observe this precaution can result personal injury.



WARNING

Be special cautions to high pressure gas

1. High pressure gas was held inside the accumulator of the breaker.
2. Do not loosen the nut unless it is necessary for maintenance.

Failure to observe this precaution can result serious injury

INTRODUCTION

1. This hydraulic breaker is designed to be used for the following purposes.
 - (1) Breaking concrete and asphalt
 - (2) Digging or breaking hard soil
 - (3) Compacting soil
 - (4) Cutting asphalt

2. **DO NOT** operate this breaker on the following situations:
 - (1) Drench part of the breaker or whole breaker into water or seawater.
 - (2) Connect with power source which its oil flow and pressure exceeds the range prescribed.
 - (3) Operating at oil temperature below 10°C or over 90°C.
 - (4) Using with the other not genuine tools
 - (5) Operation below 10° C or over 40° C.
 - (6) Use the equipment for purposes other than stated in this manual.

If you want to use this breaker in other conditions except above, always consult with us.

SPECIFICATIONS & DESCRIPTIONS

Weight	20kg (Without tool)
Dimensions	L665mmxW410mm
Working Pressure	8 ~ 11 MPa
Max. Pressure	20.6 MPa
Oil Flow B.P.M.	20.5l 1450bpm
Shank Size	Hex. 1" x 108mm
Coupling	3/8" Couplers
Back Pressure	2.5MPa
Extension Hose Power Unit)	3/8" x 10m (with
Hydraulic oil	ISO VG32, VG40 or equivalent
NOISE	84.3 dB(A)
Vibration	8.56c/sec ²

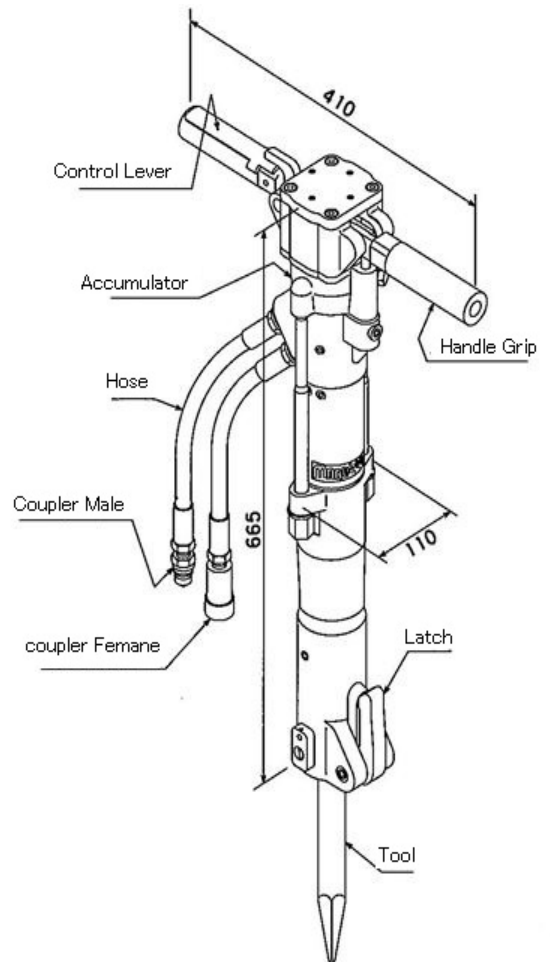

Safety Labels

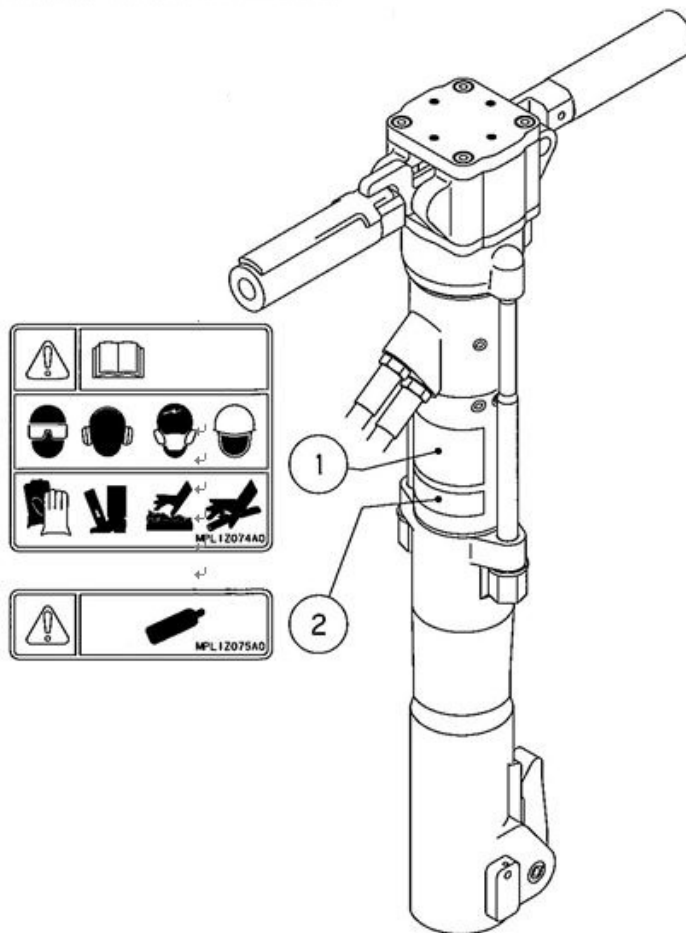

	Part No.	Part Name
①	MPL1Z074A	Label BY (warning)
②	MPL1Z075A	Label BZ (warning)

INSPECTIONS BEFORE EACH OPERATION

For the purpose of keeping the breaker in good condition, make sure the following items should be inspected each time before using. (Refer the drawing below)

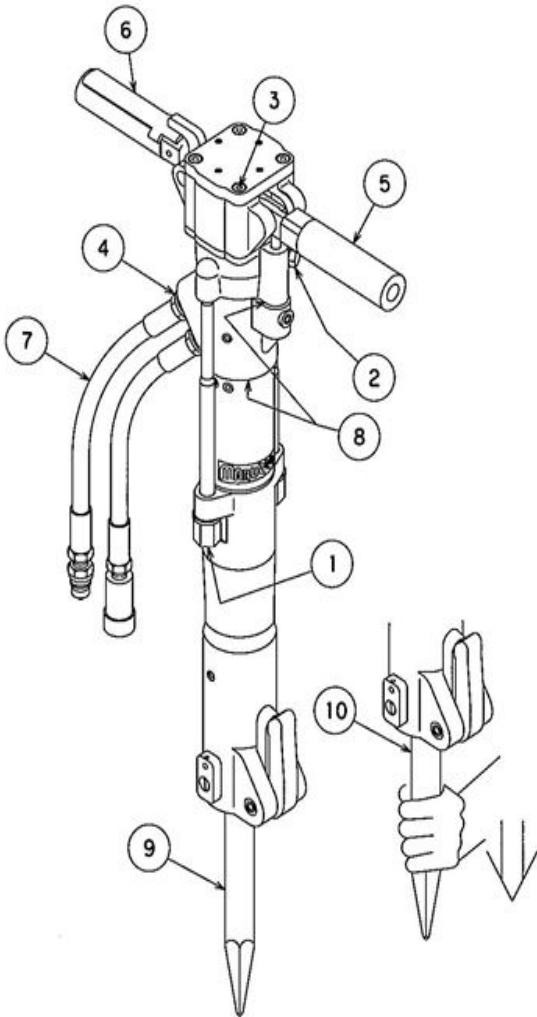

Inspection Items	Countermeasures
1. Loose nut	Tighten the loosen nut
2. Loose of plug	Tighten the plug
3. Loose of bolts	Tighten the bolts
4. Loose of hose fittings	Tighten the fittings
5. Wears of handle grips	Replace new one
6. Crack of control lever	Replace new one
7. Damage of hoses	Replace new ones
8. Oil leakage of each parts	Replace the seals
9. Damage of tool	Replace the tool
10. Loose of tool	Check the latch and replace if necessary

GUIDELINES

1. Always use Maruzen Genuine Tools. Use other than Maruzen genuine tools may cause breakage of tools which may lead to the damage of the breaker and personal injury.
2. Consult with us when using power source other than UH070 Maruzen power pack.
3. When connecting and disconnecting couplers, make sure dirt, dust and other foreign substance does not enter or attach to couplers and hoses.
4. Make sure the power source is OFF when connecting the breaker to the power source. Or changing tools (Moil point etc)
5. Maruzen original tools are highly recommended. Consult your dealer for more specifics of tools.
6. If the oil temperature is below 10°C, warm up the breaker before start operating.



7. Pay attention to the followings while operating the breaker.
 - (1) Be cautious for not being injured by the front of the tool.
 - (2) Be cautious for not being tripped by the extension hoses.
 - (3) Make sure there are no obstacles at jobsite. (Be cautious not being tripped by obstacles while operating)
 - (4) While pulling out the breaker from the broken objects, be cautious for not being fall over.
 - (5) Make sure the breaker was placed in horizontally. Fail to place the breaker horizontally after operating can cause injury by sudden falling of the breaker.
 - (6) Be cautious not to injure your back while lifting the breaker.
8. In case of sudden hydraulic hose breakage and hydraulic oil belch out. STOP the power source IMMEDIATELY.
9. Replace new hoses when they are worn or when oil exudes from them.
10. When detach couplers, a small amount of oil may slip out. Make sure that surrounding area does not get dirty by oil.
11. When detach from power source, attach two hoses to each other.

12. When frequently attach and detach to the power source, hydraulic oil will decrease accordingly. Always make sure the hydraulic oil level before operating and refill if necessary.
13. After the operation, use tool to push up the piston.
14. If the oil temperature is below 10°C, warm up the breaker before start operating.
15. For long-term storage:
 - 1) Connect breaker to hydraulic power pack, insert any wood bar (∅20~25mm, L 350mm) into front end to push up piston to the end.
 - 2) Apply antirust on piston.
 - 3) Apply oil all over breaker with wet cloth. Cover it properly and make sure it is kept in a low humidity place.
 - 4) Remove plug on front end and attach grease nipple for applying grease.



Immediately STOP the power source if the breaker does not stop after releasing the control lever. Ask Maruzen dealer for repair and service before the next operation.

OPERATION

When connect this breaker to power source other than Maruzen UH070 power unit, make sure the power source you intend to use is within the range (oil flow, pressure etc) prescribed on page 9.

Preparation

1. Unlock the latch on the breaker and insert tool (moil point etc) Turn around the tool(Hexagon tool) if it stuck on the half way of inserting.
2. Lock the latch. Make sure the tool is firmly fastened.

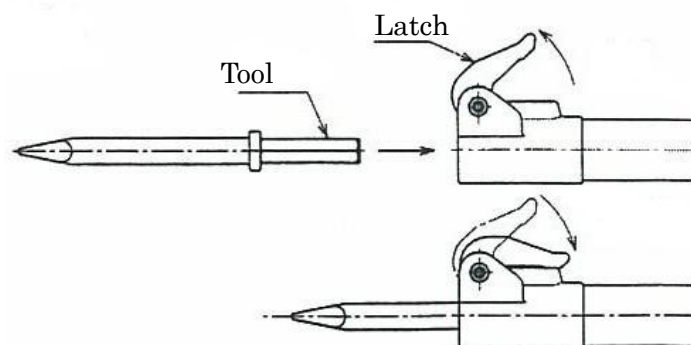

3. Make sure there is no dust or dirt inside couplers before connecting breaker to hydraulic power pack.

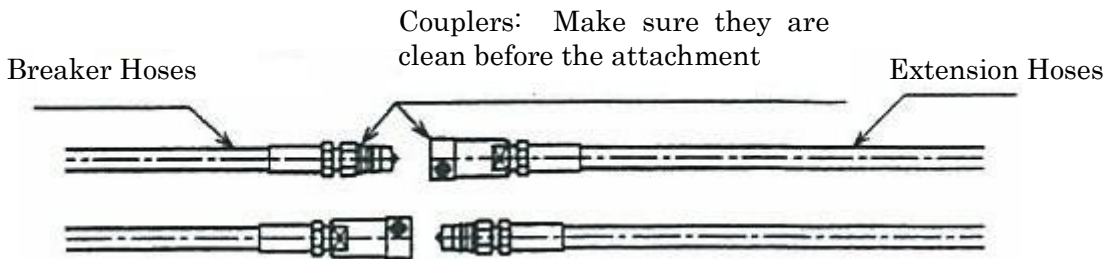

4. Active the power source. (Start the engine on the power pack)

Operation

5. The breaker and the breaking object should be on a right angle. Press down the breaker with your body weight. Grip the control lever and start hammering.

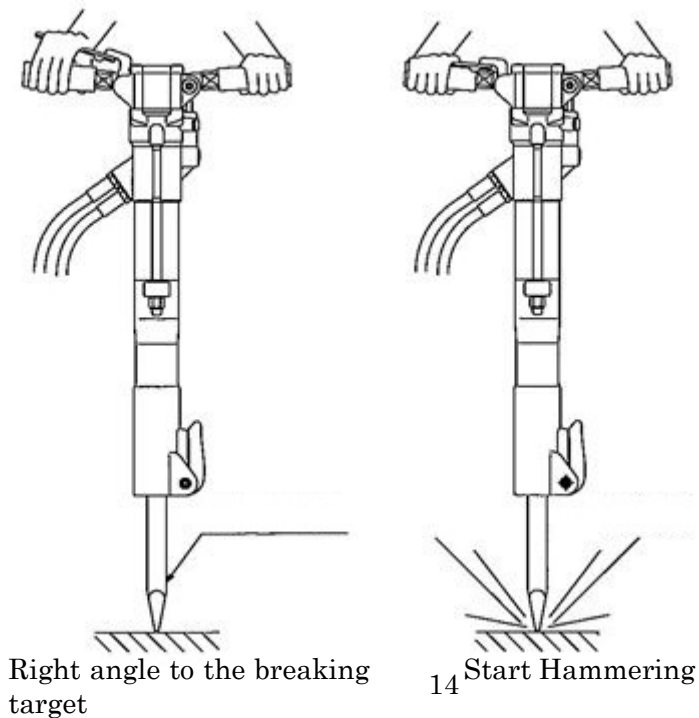

6. Do not hammer the same place for over 30 seconds. If the target object does not break within 30 seconds, change the hammering point.
7. Do not blank hammering for over 10 seconds.
8. Stop the power pack when the job has completed.
9. Push up the tool so the piston return to the position.
10. Detach the extension hoses.
11. Attach both couplers which are on the breaker together to prevent dust and dirt entering.
12. Unlock Latch, remove tool from the main body.
13. Remove mud and dirt on breaker thoroughly.

DAILY CHECK OUT

Check before each operation

1. Check if there is any oil leakage from hoses or breaker itself.
2. Check if there are any cracks or damage in tools.

PERIODICAL INSPECTION

Ask your dealer for the periodical inspections.

Inspection Items	Operating Hours
Nitrogen gas charge in accumulator	300 hours or 1 Year
Replacement of accumulator diaphragm	500 hours or 2 years
Replacement of Valve Rod O ring	500 hours or 2 years
Replacement of U-cup packing	500 hours or 2 years
Replacement of each O Ring	Every 3 years
Wear of Movable Bush	Every 250 hours or every year
Grease Movable Bushy (8g)	Every 50 hours

* Accumulator Nitrogen gas pressure: 3.5MPa (35.7kgf/cm²)

AVAILABLE TOOLS

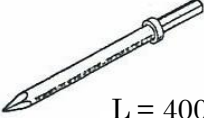
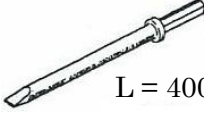
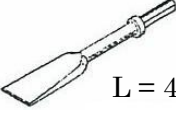
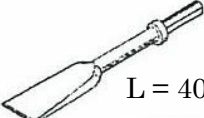
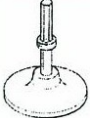
MOIL POINT	 L = 400mm	For Breaking
CONCRETE CHISEL	 L = 400mm	For Breaking
ASPHALT CHISEL	 L = 400mm	For Cutting Asphalt
SHOVEL	 L = 400mm	For Digging Hard Soil
TAMPING RAMMER	 L = 400mm	For Compacting Soil and Sand

TROUBLE SHOOTING

Symptoms	Causes	Countermeasures
Grip the control lever but does not start	<ol style="list-style-type: none"> 1. Power source is off (Switch lever is in OFF position) 2. Hoses are not connected 3. Couplers are not connected properly 4. Relief valve pressure is set too low 5. Damage of control valve 6. Control valve is stuck by foreign substances 7. High pressure side and oil return side was connected inversely 	<ol style="list-style-type: none"> 1. Start the power source (Turn the switch lever to On position) 2. Connect hoses 3. Check out if all the couplers have been connected properly 4. Adjust pressure to 140~210kgf/cm² (13.7~20.6MPa) * 5. Replace a new control valve * 6. Disassemble breaker, clean and remove dirt and dust between control valve and valve body * 7. High pressure hoses is connected to the upper side of the breaker
Functioning but weak hammering or low hammering speed	<ol style="list-style-type: none"> 1. Low rate of oil flow from power source 2. Pressure in relief valve in power source is set too low 3. Control valve does not function properly 4. Back pressure is too high 	<ol style="list-style-type: none"> 1. Turn the engine rotation rate up and increase the rate of oil flow (Adjust oil flow to the necessary rate) 2. Check displacement of hydraulic pump* 3. Adjust pressure to the range of 11.7~20.6MPa) *Remove and clean the joint of control valve and valve body * 4. Use widen or shorter hose on the oil

	5. Moveable Bush got stuck	returned side to lower the back pressure to 2.5MPa or under. 5. Disassemble and clean the breaker*
Hammering in normal speed, but weak hammering	1. Low accumulator gas pressure 2. Damage of accumulator diaphragm 3. Temperature of hydraulic oil is abnormally high.	1. Refill Nitrogen gas 35.7kgf/cm ² (3.5MPa) * 2. Replace diaphragm * 3. Check power source. Clean radiator and fan
Strong hammering and in high speed	1. High rate of oil flow	1. Turn the engine rotation rate down to decrease the rate of oil flow (Adjust oil flow to the right range)
The breaker stops hammering during operation	1. Couplers are not connected 2. Damage of control valve	1. Check each connected parts 2. Replace a control valve *
Oil leakage from control lever	1. Damage, wear or harden of O ring	1. Replace O ring *
Profuse Oil leakage from front end	1. Damage of U cup packing 2. Damage of U cup packing due to the scratch of piston rod.	1. Replace U cup packing * 2. Replace U cup packing, remove the scratch on piston rod *
Latch is nearly coming off	1. Damage of lock spring 2. Wear of latch	1. Replace lock spring * 2. Replace latch *
High pressure hose shakes intensely	1. Damage of accumulator diaphragm	1. Replace diaphragm *
Release the control valve but the breaker does not stop	1. Foreign substance is caught in the valve rod	1. Disassemble, clean and adjust *

For items with *, ask Maruzen dealers for service and maintenance.

EXPLODED VIEW MODEL BH20EV

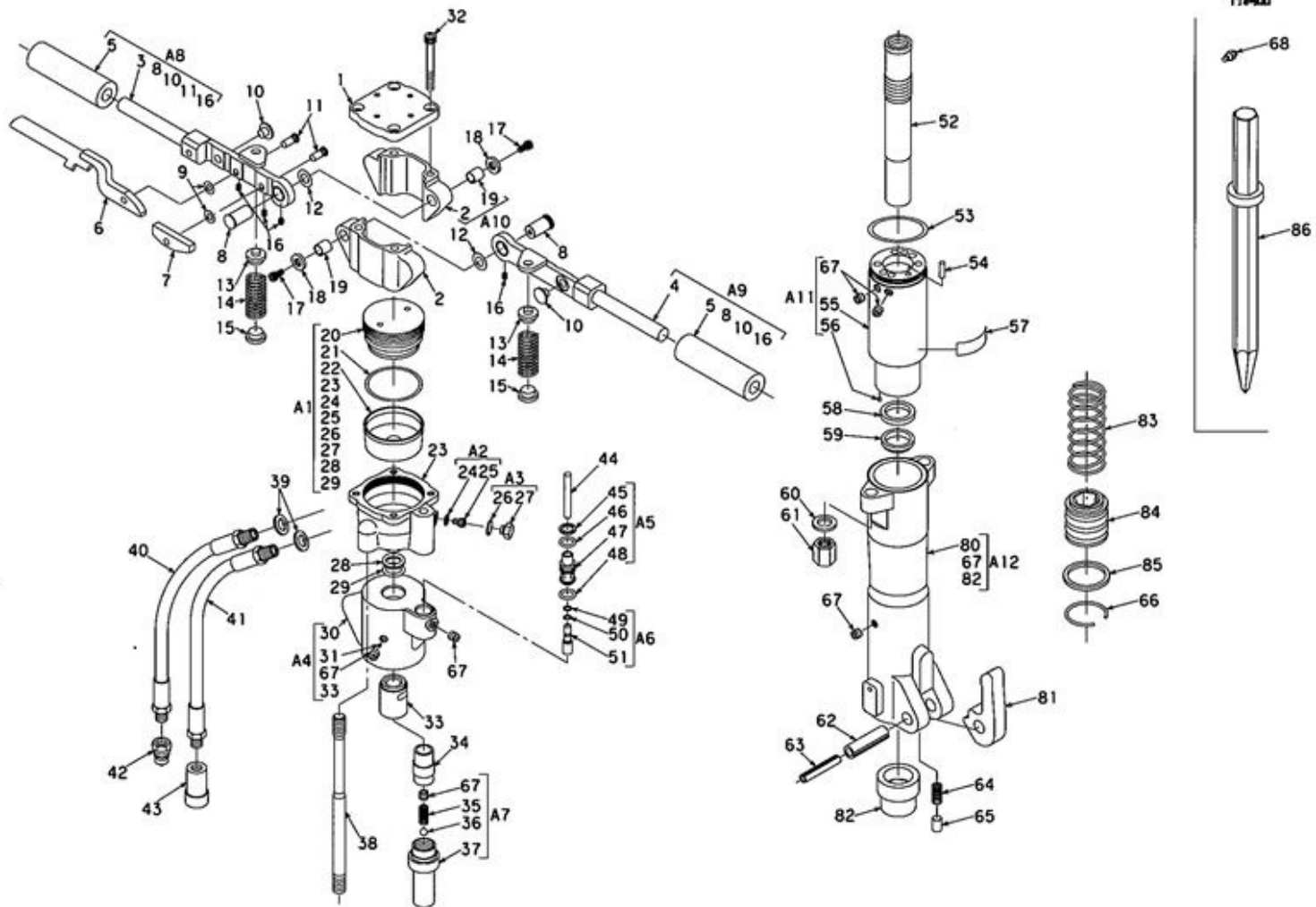

N o .	Part No.	Part Name	Q'ty	N o .	Part No.	Part Name	Q'ty
1	MB19Z010A	Cover	1	22	MB02E006A	Diaphragm	1
2	MB19Y001B	Cover	2	23	MB19Y002A	Shell	1
*3	MB35Z009A	Handle (L)	1	24	WS-06<<<<<<<<<<BH	Seal Washer	1
*4	MB19Z023B	Handle (R)	1	*25	1120-413-D	Cap Bolt	1
5	1120-414	Handle Grip	2	26	OS-15	O-Ring	1
6	MB35Z010A	Control Lever	1	27	MB35Z017A	Plug	1
7	MB19Z016A	Lever	1	28	OBP-22	Back up Ring	1
8	MB19Z008B	Pin	2	29	OP-22	O-Ring	1
9	MB19Z035A	Washer	2	*30	MB32X002A	Valve Body	1
10	MB19Z021A	Pad	2	31	M2LTE120 A	M6 Orifice(φ2.6)	1
11	MB19Z006A	Pin	2	32	BH-8×70 (Zn)	Bolt	4
12	MB19Z024B	Washer	2	*33	MB32Z003A	Valve Bush	1
13	MB19Z020A	Spring Washer	2	34	M1XTE108A	Control Valve	1
14	MB19Z007A	Spring	2	35	M1HTE107A	Spring (P)	1
15	MB19Z019A	Spring Washer	2	36	QB-5/16	Steel Ball	1
16	SH-5x8 (Togarisaki)	Stopper Screw	4	*37	MB32Z004A	Inner Tube (V)	1
17	BH-6×12	Bolt	2	38	MB19Z009A	Through Bolt	2
18	MB19Z030A	Guide Bush	2	39	WS-18<<<<<<<<<<BH	Seal Washer	2
19	K5@1620	DU Bush	2	40	21091・3・35-	Hose	1
20	MB19Z011A	Lid	1	41	21091・3・50-	Hose	1
21	CO-0644	O-Ring	1	42	QC-03M	Coupler (Male)	1

No.	Part No.	Part Name	Q'ty	No.	Part No.	Part Name	Q'ty
43	QC-03F	Coupler (Female)	1	64	1110-410	Lock Spring	1
44	MB19Z014A	Push Rod	1	65	M1KTE173A	Lock Pin	1
45	OBP-14	Back up Ring	1	66	MB37Z001A	Ring	1
46	OP-14	O-Ring	1	67	BPH1-PT1/8	Plug	10
*47	M2LTE108A	Valve Guide	1	68	GN-01	Grease Nipple (Accessory)	1
48	OP-12.5	O-Ring	1	*80	MB37X015A	Front End (K)	1
49	OBP-5	Back up Ring	1	81	1110-402	Latch	1
50	OP-5	O-Ring	1	*82	MB37Z012A	Fixed Bush	1
*51	M1KTE111A	Valve Rod	1	83	MB37Z011A	Spring	1
52	MB18Y046A	Piston	1	84	MB37Z013A	Movable Bush	1
53	OG-60	O-Ring	1	85	MB37Z014A	Washer	1
54	PR-6x20	Pin	1	86	MZ42-002D	Moil Point (Accessory)	1
*55	M1XTD104B	Cylinder (A)	1				
56	MB850-040	Expander	1				
57	MB29Z023A	Maruzen Sticker 2	1				
58	IUIS 30、40、6	U Cup Packing	1				
59	LBI 30、38、5、6.5	Dust Seal	1				
60	WF-14 2L	Washer	2				
61	1120-423	Nut	2				
62	PR-16x60	Pin	1				
63	PR-10x60	Pin	1				

No.	Code	Descriptions	Qty	
A 1	MB19Z051A	Accumulator Assy	1	20, 21, 22, 23, 24, 25, 26, 27, 28, 29
A 2	MB24Z509A	Cap Bolt Assy	1	24, 25
A 3	MB35Z075A	Plug Assy	1	26, 27
A 4	MB32Z500A	Valve Body Assy	1	30, 31, 33, 67(4)
A 5	M2LTZ506A	Valve Guide Assy	1	45, 46, 47, 48
A 6	M1XTZ505A	Valve Rod Assy	1	49, 50, 51
A 7	MB32Z501A	Inner Tube Assy	1	35, 36, 37, 67
A 8	MB35Z501A	Handle (L) Assy	1	3, 5, 8, 10, 11(2), 16(3)
A 9	MB19Z040A	Handle (R) Assy	1	4, 5, 8, 10, 16
A 10	MB19Z044A	Cover Assy	2	2, 19
A 11	MB19Z052A	Cylinder Assy	1	55, 56(1), 67(4)
A 12	MB37Z502A	Front End (K) Assy	1	67, 80, 82
A 13	MB19Z039A	Seal Kit	1	21, 24, 26, 28, 29, 39(2), 45, 46, 48, 49, 50, 53, 58, 59