

MARUZEN

HYDRAULIC HANDHELD PILE DRIVER

MODEL KH240V

OPERATING MANUAL



CAUTION

FOR THE SAFETY PURPOSE, PLEASE READ THIS MANUAL THOROUGHLY BEFORE ATTEMPTING TO USE THIS PILE DRIVER. ANY FALES OPERATING PROCEDURES WILL CAUSE DAMAGES OF THE MACHINE. ALWAYS KEEP THIS MANUAL TO AN EASILY ACCESSABLE PLACE.



MARUZEN KOGYO CO., LTD.

(Revised April 20, 2015)

FOREWORD

This manual is an important part of your equipment. It provides rules and guidelines which will help you use this machine safely and effectively. You **MUST** familiarize yourself with the functions and operations by reading the manual thoroughly before you begin using this machine. For your safety, it is especially important that you read and observe all precautions in this manual and on the machine. The precautions **MUST** be followed strictly at all times when performing operation and maintenance. * Fail to follow the guidelines and safety alerts in the manuals and on the machine, or use this machine in alternative ways from the manuals may result in system failure or serious personal injury.

Keep this manual with the equipment or in an easily accessible place in all times for future reference. Make sure all personnel involved in working on this machine can consult it periodically. In case this manual should be lost or damaged, immediately contact us or your dealer to purchase a new copy.

We recommend you always use Maruzen genuine components and parts. Replacing components and parts from other sources may cause damages to this machine and endanger operators.

MARUZEN KOGYO CO., LTD.
155-8 NAGABUSE, MISHIMA-SHI,
SHIZUOKA-KEN, 411-0824, JAPAN

CONTENTS

Safety Information.....	4 ~ 7
Safety Alert Classifications.....	4
Safety Alerts	5 ~ 7
Specifications & Descriptions.....	8
Precaution Labels and Positions	9
Inspection before Each Operation.....	10
Guidelines	11 ~ 12
Operation.....	13
Periodically Inspection	14
Troubleshooting.....	15 ~ 16
Exploded View.....	17
Parts List.....	18 ~ 19

SAFETY INFORMATION

To enable you to use this machine safely, safety precautions and labels are given in this manual and affixed to the machine to give explanations of situations involving potential hazards and of the methods of avoiding such situations.

SAFETY ALERT CLASSIFICATIONS

The following safety alert symbols are used to inform you that there is a potential hazardous situation that may lead to personal injury or damage.

In this manual and on machines labels, the following safety alert symbol are used to express the potential level of hazard.



Indicates an imminently hazardous situation which, if not avoided, could result in death or serious injury.



Indicates a potentially hazardous situation which, if not avoided, could result in death or serious injury.

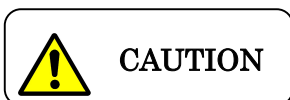

Indicates a potentially hazardous situation which, if not avoided, could result in minor or moderate injury.

**** Safety alert symbols are to emphasize all operation which, if not strictly followed, could result in a life-threatening situation, bodily injury or damage to equipment.**

SAFETY ALERTS

DO NOT OPERATE THE MACHINE UNLESS THE FOLLOWING SAFETY INSTRUCTIONS HAVE BEEN THOROUGHLY READ AND UNDERSTOOD!



WARNING

Before operating the equipment, be sure to wear personal protective equipments such as follows:

1. Helmet
2. Protective goggles
3. Protective boots
4. Safety gloves
5. Hearing Protection



WARNING

Do not operate the equipment if you are or if your

1. taking medication, feeling drowsy, feeling unwell or feeling tired.
2. under the influence of drugs or alcohol.
3. hands, feet, lower back or other parts of your body hurt or being injured.

* Failure to observe this precaution can result serious injury or even death.

**CAUTION**

Do not touch the machine with your bare hands

1. The oil tank may become hot under continuous running.
Do not touch the equipment with your bare hands.

2. Tools may become hot under continuous use, make sure to wear gloves before any contact with the tools.

* Failure to observe this precaution can result getting burned

**CAUTION**

When lending someone the equipment

Make sure the safety instructions have been thoroughly read and fully understood by the person who is going to use the equipment.

**WARNING**

Be special cautions to high pressure gas

1. High pressure gas was held inside the accumulator of the breaker.

2. Do not loosen the nut unless it is necessary for maintenance.

Failure to observe this precaution can result serious injury

INTRODUCTION

1. This hydraulic pile driver is designed to be used for driving piles and other application into soil ground.

2. **DO NOT** operate this driver on the following situations:
 - (1) Drench part of the driver or whole driver into water or seawater.
 - (2) Connect with power source of which oil flow and pressure exceeds prescribed.
 - (3) Operating with oil temperature below 10°C or over 100°C.
 - (4) Attaching to other construction machinery.
 - (5) Use the driver for the purposes other than stated in this manual.

SPECIFICATIONS & DESCRIPTIONS

Overall Weight	24.5kg
Overall Dimensions	629mm x 265mm x 154mm
Working Pressure	80~120kgf/cm ² (7.8~11.8Mpa)
Max. Pressure	210kgf/cm ² (20.6MPa)
Flow Range	20L/min
Blow per Minute	1080bpm
Capacity	φ80mm (φ100、120 mm Option)
Allowable Back Pressure	2.5MPa
Coupling	3/8" Couplers
Recommendable Oil	ISO VG32/ 46

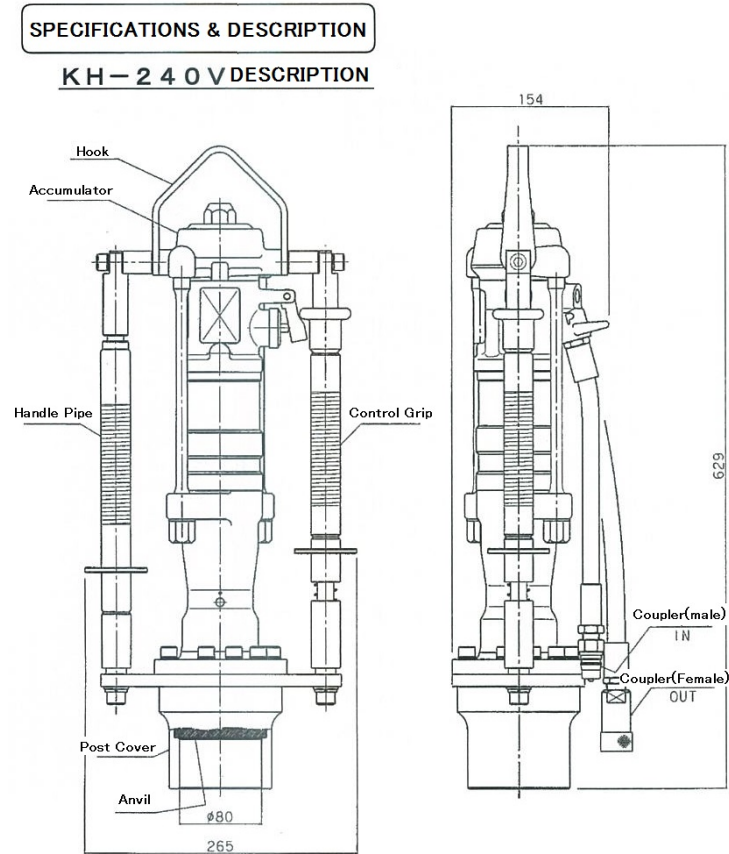

PRECAUTION LABELS AND POSITIONS

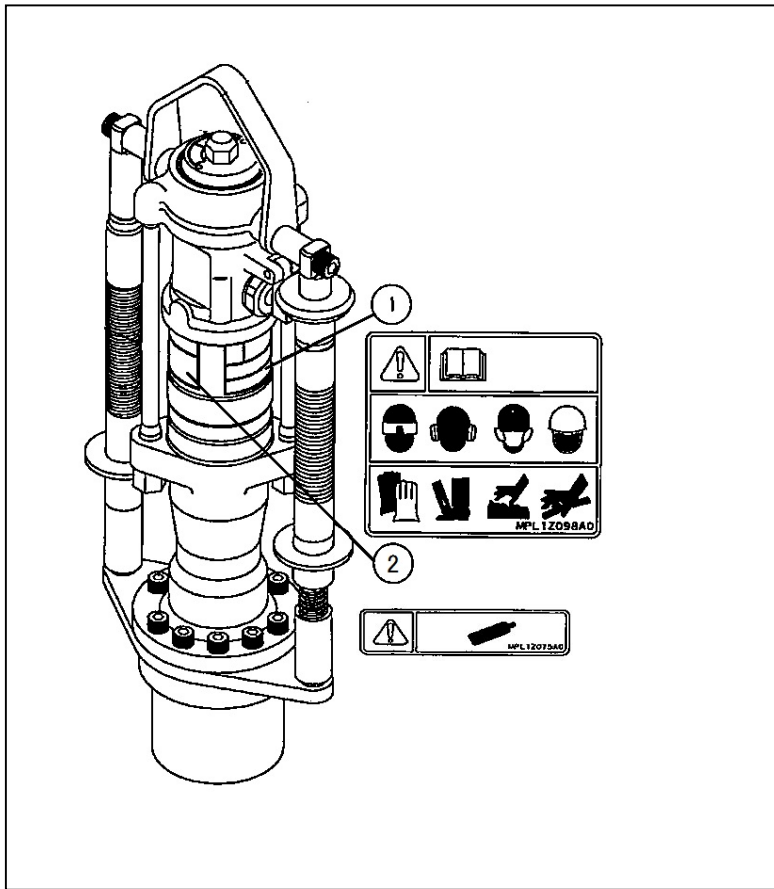

	PART NO.	PART NAME
1	MPL1Z093A	LABEL CP (WARNING)
2	MPL1Z098A	LABEL CS (WARNING)

INSPECTIONS BEFORE EACH OPERATION

For the purpose of keeping the pile driver in good condition, make sure the following inspection items are done each time before using. (Refer the drawing on the right)

Inspection Items	Countermeasures
1. Loose cap nut①	Re-tighten the loosen cap nut
2. Loose nut②	Re-tighten the loosen nut
3. Loose bolts③④⑤	Re-tighten loosen bolts
4. Loose hose fittings⑥	Re-tighten hose fittings
5. Oil leakage⑦⑧⑨⑫	Repair
6. Damage of hoses⑩	Replace new ones
7. Moving range of anvil⑪	Clean inside

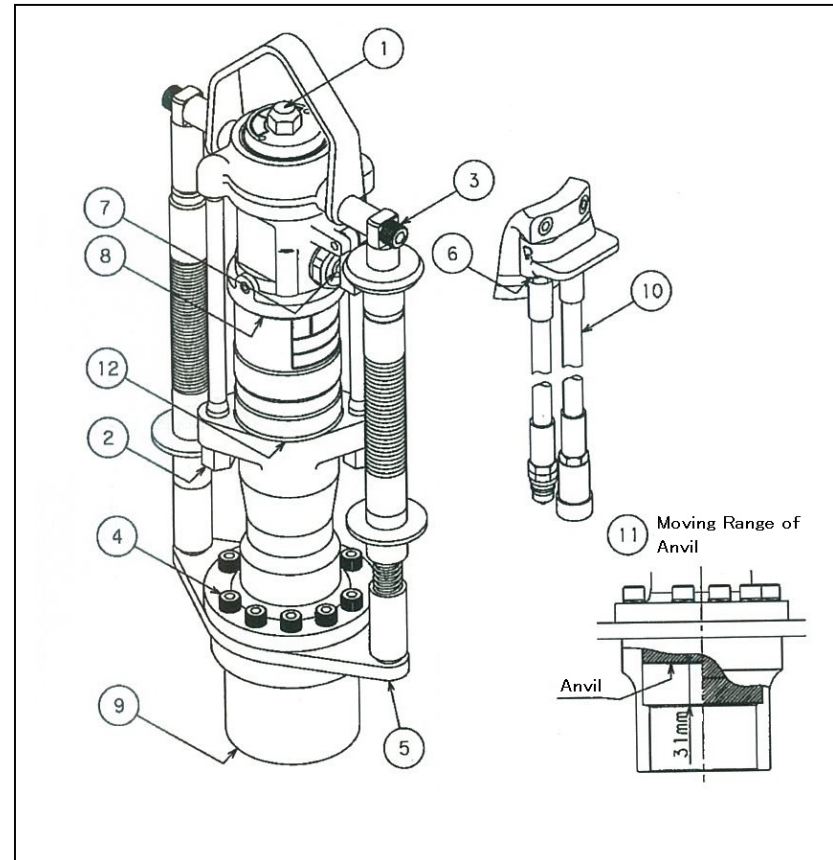
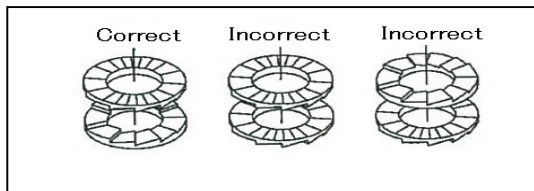

GUIDELINES

Following these guidelines while using this pile driver:

- (6) When intend to use other power source (other than Maruzen hydraulic power units), make sure the pressure and oil flow is in the range prescribed
- (7) When connecting and disconnecting couplers, make sure dirt, dust and other foreign substance does not enter or attach to couplers and hoses.
- (8) Make sure the power source is OFF when connecting the pile driver to the power source with hoses.
- (9) If the oil temperature is below 10°C, warm up the breaker before start operating.
- (10) Make sure grease and oil spot on handle grip or handle pipe has been fully removed. Oil spot or grease left on handle grips or handle pipe can cause the pile driver slip during operating and endanger operators.



(11) Pay attention to the followings while operating the pile driver.

- (1) Be cautious for not being tripped by the extension hoses.
- (2) Be cautious for your footing. Clear the work area of objects which might operators to trip and fall.
- (3) Make sure the pile driver is placed horizontally. Fail to place the pile driver horizontally after operating can cause injury by sudden falling of the pile driver.
- (4) Be cautious not to injure your back while lifting the pile driver.
- (5) While attaching pile driver on the top of the applications (wood, steel pipes and etc), make sure the applications is well supported. Fail to have the application well-supported can cause the pile driver to fall and injure operators.
- (6) Use wire to lift the pile driver.
- (7) Do not leave pile driver unattended on applications.
- (8) Be cautious for your footing while operating the pile driver.

(12) In case of sudden hydraulic hose breakage and hydraulic oil belch

out. STOP the power source IMMEDIATELY.

- (13) Replace new hoses when they are worn or when oil exudes from them.
- (14) When detach couplers, a small amount of oil may slip out. Make sure that surrounding area does not get dirty by oil.
- (15) When detach from power source, attach two hoses to each other.
- (16) When the pile or pipe does not enter into the ground, stop the operation and check if some obstacles are in the ground. Continuous operation will cause the damage of the machine and make the deforming of pile or pipe and stuck inside of machine. When the pipe or pipe is stuck inside of the post cover, don't strike body by hammer but swing the machine to release the pile or pipe.
- (17) Don't put the post cover head into the ground or under water. Otherwise, mud or water enters into post cover and make the damage of the machine.

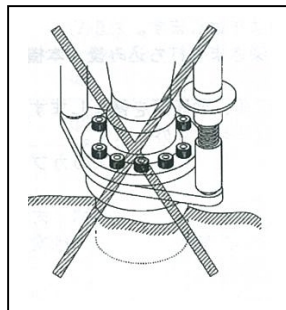
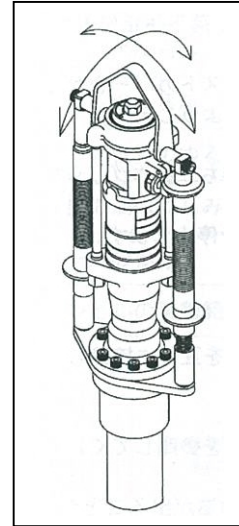

Immediately STOP the power source if the pile driver does not stop operating after releasing the control grip. Ask Maruzen dealer for repair and service before the next operation.

OPERATION

1. Connect the pile driver with hydraulic power source.
2. Start the power unit or other power source, let it runs for a while to warm up the engine.
3. Use $\varnothing 4\text{mm}$ wire to lift the pile driver (Refer to the drawing on the right)
4. Place pile vertically on the point which you intended to drive in. Set the pile driver on the top of pile. Be cautious not to let the pile driver falls
5. Grip the control grip and handle pipe. Press the pile driver downward. Start the pile driver by clasping the control grip downward.
6. Make sure that pile stays vertically without inclination.
7. While pile has been driven in to the desired depth, Stop the pile driver.
8. Remove the pile driver from the pile.
9. Stop the power source and detach the connection hoses.

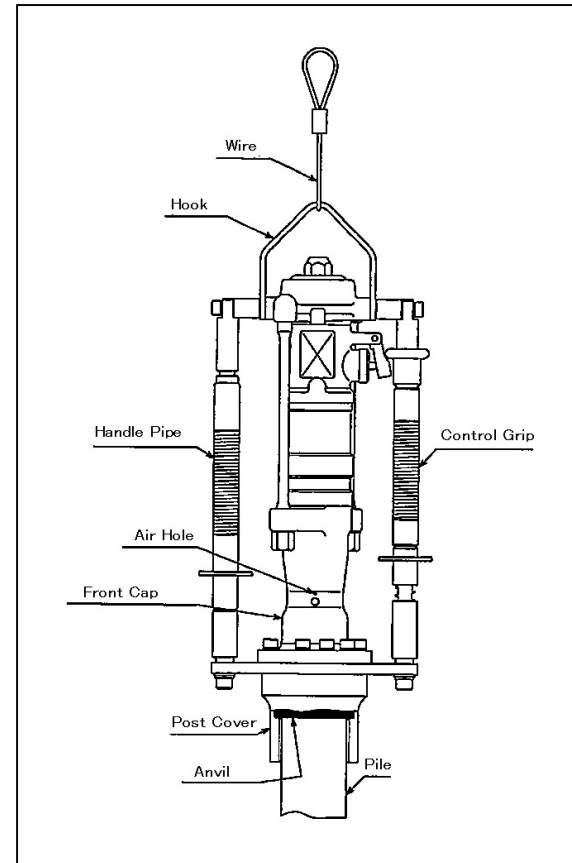

PERIODICAL INSPECTION

Ask your dealer for the periodical inspections.

Inspection Items	Operating Hours
Accumulator Nitrogen gas charge	300 hours or 1 Year
Change accumulator diaphragm	500 hours or 2 years
Change O ring in valve body	500 hours or 2 years
Change U cup packing	500 hours or 2 years
Change all O rings	3 years
Grease	6 months

* To grease up, replace No.68 grease nipple with No. 53 plug and use grease gun for 10 to 15 times.

For long storage, always grease up as above instruction and apply anti-rust oil to anvil from the post cover.

Clean the whole body with oiled rag and store the machine in dry condition with cover.

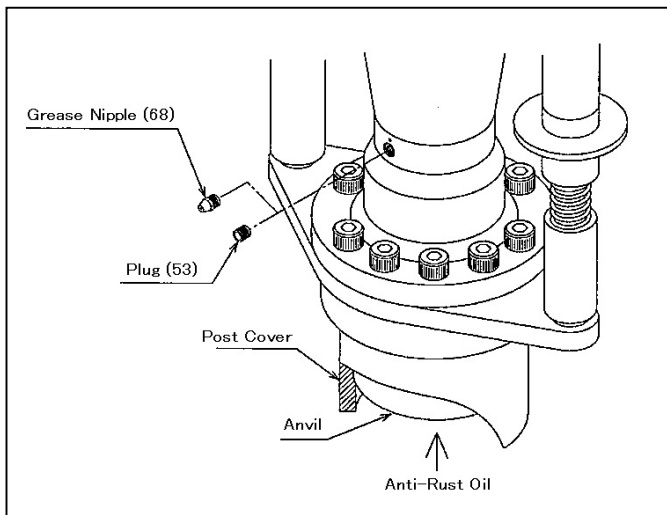

TROUBLE SHOOTING

Symptoms	Causes	Countermeasures
Grip the control lever but does not start	<ol style="list-style-type: none"> 1. Power source is off (Switch lever is not in ON position) 2. Hoses are not connected 3. Couplers are not connected properly 4. Relief valve pressure is set too low 5. Damage of control grip 6. Control grip is not functioning 7. Outlet side and oil return side was connected inversely 8. Ware of control grip 	<ol style="list-style-type: none"> 1. Start the power source (Turn the switch lever to On position) 2. Connect hoses 3. Check out if all the couplers have been connected properly 4. Adjust pressure to 120~140kgf/cm² (11.8~13.7MPa) * 5. Replace a new control lever * 6. Disassemble breaker, clean and remove dirt and dust between control lever and valve body * 7. High pressure hoses is connected to the upper side of the breaker 8. Replace new control grip *
Functioning but weak hammering or low hammering speed	<ol style="list-style-type: none"> 1. Low rate of oil flow from power source 2. Pressure in relief valve in power source is set too low 3. Control valve does not function properly 4. Back pressure is too high 	<ol style="list-style-type: none"> 1. Turn the engine rotation rate up and increase the rate of oil flow (Adjust oil flow to the necessary rate) 2. Adjust pressure to the range of 120~140kgf/cm² (11.8~13.7MPa) * 3. Remove and clean the joint of control lever and valve body * 4. Inspect return side hose
Normal speed but weak hammering	<ol style="list-style-type: none"> 1. Low gas pressure in accumulator 2. Damage of accumulator diaphragm 	<ol style="list-style-type: none"> 1. Nitrogen gas charge * Charge pressure 3.9MPa (40kgf/cm²) 2. Replace new diaphragm *

Strong hammering and in high speed	1. High rate of oil flow	1. Turn the engine rotation rate down to decrease the rate of oil flow (Adjust oil flow to the right range)
An abrupt stop during operation	1. Couplers are not connected 2. Damage of control valve	1. Check each connected parts 2. Replace a control valve *
Oil leakage from control lever	1. Damage, wear or harden of O ring	1. Replace O ring *
Profuse Oil leakage from front end	1. Damage of U cup packing 2. Damage of U cup packing due to the scratch of piston rod.	1. Replace U cup packing * 2. Replace U cup packing, remove the scratch on piston rod *
High pressure hose shakes intensely	1. Damage of accumulator diaphragm	1. Replace diaphragm *
Release the control valve but the breaker does not stop	1. Foreign substance is caught in the valve rod	1. Disassemble, clean and adjust *

For items with *, ask Maruzen dealers for service and maintenance.

EXPLODED VIEW

KH-240V

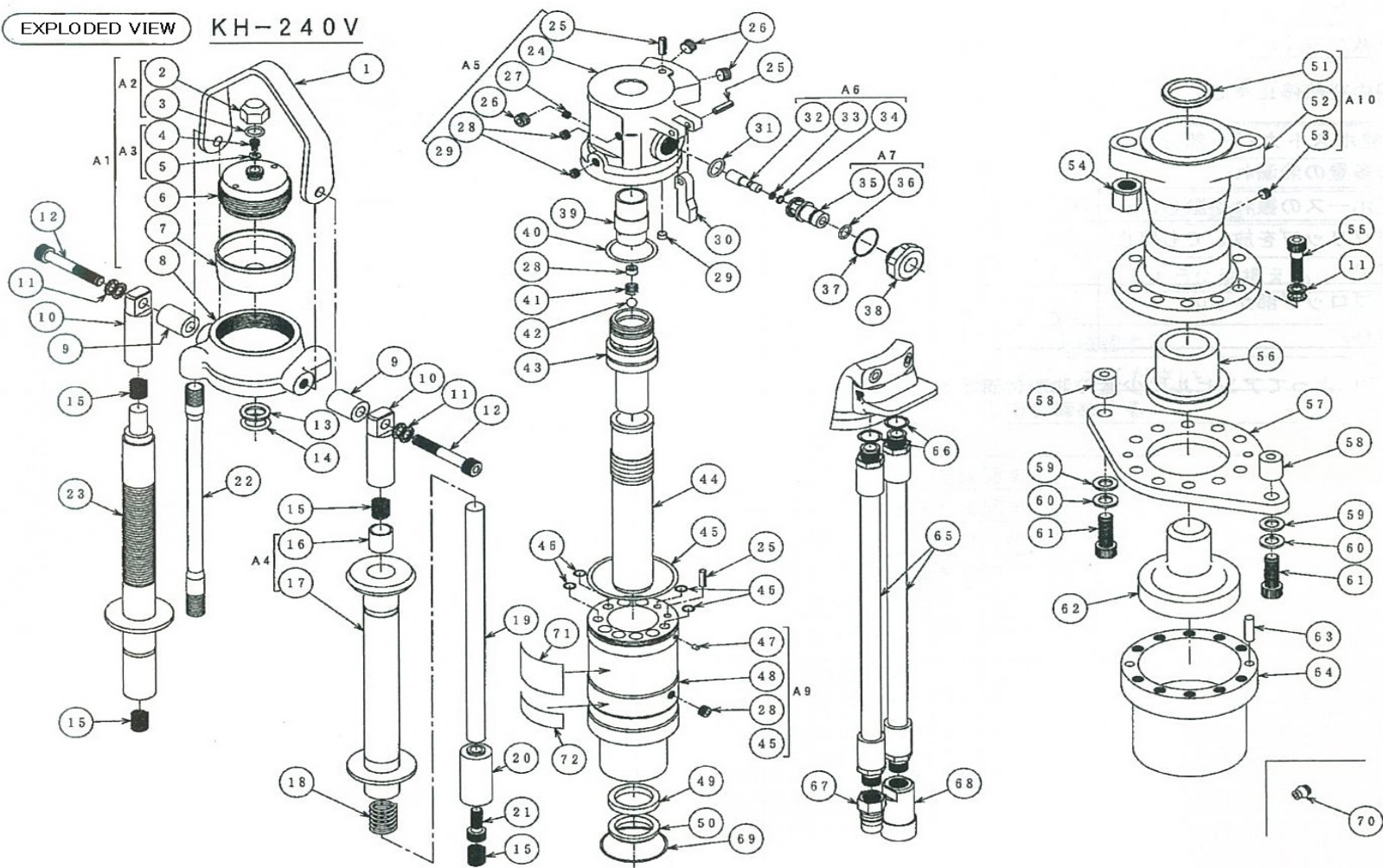

PARTS LIST (I) MODEL KH240V * only can be supplied as assembly parts

No.	Code	Descriptions	Q'ty	No.	Code	Descriptions	Q'ty
1	MB38Z021A	Hook	1	25	PR-6x20	Pin	3
*2	M1KTE108A	Cap nut	1	26	BPH1-PT1/4	Plug	3
3	OS-22.4	O-ring	1	27	MB13Z018A	Orifice plug(φ 4.0)	1
*4	1120-413-D	Cap bolt	1	28	BPH1-PT1/8	Plug	6
5	WS-06<<<<<<<<BH	Seal washer	1	29	BPH1-PT1/16	Plug	1
6	M1XTE110A	Lid	1	30	MB38Z023A	Cam	1
7	MB02E006A	Diaphragm	1	31	FR307W	O-ring	1
8	MB38Y001A	Shell	1	*32	M1KTE111A	Valve rod	1
9	MB38Z022A	Caller	2	33	OP-5	O-ring	1
10	MB38Z018A	Spring holder A	2	34	OBP-5	Back up ring	1
11	NL-10	Washer	12	*35	M1KTZ280A	Valve guide	1
12	BH-10x65	Bolt	2	36	CO-0601	O-ring	1
13	OBP-22	Back-up ring	1	37	CO-0621	O-ring	1
14	OP-22	O-ring	1	*38	M1KTZ281A	Bush	1
15	51-1635	Spring	4	39	MB38Z007A	Control valve	1
16	K5B1620	DU bush	1	40	OP-38	O-ring	1
*17	MB38Y016A	Operating grip	1	41	M1HTE107A	Spring (P)	1
18	5549	Spring	1	42	QB-5/16	Steel ball	1
19	MB38Z015A	Handle shaft	1	*43	MB38Y008A	Inner tube	1
20	MB38Z020A	Spring holder B	1	44	MB38Y009A	Piston	1
21	BH-10x25	Bolt	1	45	OG-75	O-ring	1
22	MB38Z013A	Through bolt	2	46	FR0329W	O-ring	4
23	MB38Z017A	Handle pipe	1	47	MB850-040	Kenick expander	3
*24	MB38X003A	Valve body	1	*48	MB38X010A	cylander	1

No.	Code	Descriptions	Q'ty	No.	Code	Descriptions	Q'ty
49	IUIS 35.5, 45, 6	U-cup packing	1	61	BH-12x35	Bolt	2
50	LBI 35.5, 43.5, 5, 6.5	Dust seal	1	62	MB38Z012A	Anvil	1
51	FD2149A0	Dust seal	1	63	PFB-8x32	Pin	2
*52	MB38X005A	Front cap	1	64	MB18Y070A	Post cover	1
53	BPH1-PT1/8	Plug	1	65	KH01Z572A	3/8 O-ring port hose	2
54	MB38Z014A	Nut (M16)	2	66	OP-14	O-ring	2
55	BH-10x40	Bolt	10	67	QC-03M	Coupler (male)	1
56	MB38Z011A	Chisel bushing	1	68	QC-03F	Coupler(female)	1
57	MB38Z024A	Flange	1	69	CO 7772A	O-ring	1
58	MB38Z019A	Boss	2	70	GN-01	Grease nipple	1
59	WP-12	Washer	2	71	MB38Z028A	Label	1
60	WS-12	Washer	2	72	MB29Z023A	Label	1

Assembly Parts

No	Code	Descriptions	Q'ty	Content
A1	MB38Z501A	Accumulator Assy	1	2,3,4,5,6,7,8
A2	MB24Z508A	Cap nut Assy	1	2,3
A3	MB24Z509A	Cap bolt Assy	1	4,5
A4	MB38Z506A	Operating grip Assy	1	16,17
A5	MB38Z502A	Valve body Assy	1	24,25,26(3),27,28,29
A6	M1XTZ505A	Valve rod Assy	1	32,33,34
A7	M1XTZ510A	Valve guide Assy	1	35,36
A8	MB38Z503A	Inner tube Assy	1	28,41,42,43
A9	MB38Z504A	Cylinder Assy	1	28(4),45,47(3),48
A10	MB38Z505A	Front cap Assy	1	51,52,53,56
A11	MB38Z500A	Seal kit Assy	1	3,5,13,14,31,33,34,36,37,40,45,46(4),49,50,51