

MARUZEN

HYDRAULIC POWER UNIT

MODEL UH070

(UH070-3)

OPERATING MANUAL

Original Instructions



FOR THE PURPOSE OF SAFETY, PLEASE READ THIS MANUAL THOROUGHLY BEFORE ATTEMPTING TO USE THIS BREAKER. ANY INCORRECT OPERATING PROCEDURES WILL CAUSE DAMAGE TO THE MACHINE. ALWAYS KEEP THIS MANUAL IN AN EASILY ACCESSIBLE PLACE.



MARUZEN KOGYO CO., LTD.

(Revised July 06, 2023)

FOREWORD

This manual is intended for use by those who have undergone training at the manufacturer or dealer.

This manual is an important part of your tool. It provides rules and guidelines that will help you to see this machine safely and effectively. You **MUST** familiarize yourself with the functions and operations by reading the manual thoroughly before you begin using this machine. For your safety, it is especially important that you read and observe all precautions in this manual and the labels on the machine. The precautions **MUST** be followed strictly at all times when performing operation and maintenance.

* Failure to follow the guidelines and safety alerts presented in the manual and on the machine, or use of this machine for any other purpose than described in the manual, may result in system failure or serious personal injury.

Keep this manual with the tool and in an easily accessible place for future reference. Make sure all personnel involved in working on this machine can consult it periodically. In case this manual should be lost or damaged, immediately contact us or your dealer to purchase a new copy.

We recommend that you always use Maruzen genuine components and spare parts. Using components and spare parts from other sources may cause damage to this machine and endanger operators.

MARUZEN KOGYO CO., LTD.
155-8 NAGABUSE, MISHIMA-SHI,
SHIZUOKA-KEN, 411-0824, JAPAN

CONTENTS

Safety information	4 ~ 8
Safety alert classifications.....	4
Safety alerts	5 ~ 8
Introductions	9
Specifications & Descriptions.....	10
Precaution labels and positions.....	11
Guidelines	12
Operation.....	13 ~ 18
Maintenance (Daily inspection)	18
Maintenance (Periodical inspection).....	19
Troubleshooting.....	20 ~ 21
Exploded view I	22
Exploded view II	23
Parts list.....	24 ~ 25
EC Declaration of conformity	26

SAFETY INFORMATION

To enable you to use this machine safely, safety precautions are presented in this manual and label are affixed to the machine to provide explanations of situations involving potential hazards and how to avoid them.

SAFETY ALERT CLASSIFICATIONS

The following safety alert symbols are used to inform you that there is a potential hazardous situation that may lead to personal injury or damage.

In this manual and on machine labels, the following safety alert symbols are used to express the potential level of hazard.



Indicates an imminently hazardous situation which, if not avoided, will result in death or serious injury.



Indicates a potentially hazardous situation which, if not avoided, could result in death or serious injury.



Indicates a potentially hazardous situation which, if not avoided, may result in injury or property damage.

**** Safety alert. Symbols are to emphasise all operations which, if not strictly followed, could result in a life-threatening situation, bodily injury or damaged tool.**

SAFETY ALERTS

DO NOT OPERATE THE MACHINE UNLESS THE FOLLOWING SAFETY INSTRUCTIONS HAVE BEEN THOROUGHLY READ AND UNDERSTOOD!



WARNING

Read and understand all of the instructions and safety information in this manual before operating.



WARNING

Pay special attention to high-pressure gas.

There is a risk of sudden breakage of hydraulic hoses which causes the oil inside to blow out.

1. Depressurize the machine before disconnecting any hoses.
2. Do not check for oil leaks with your bare hands since high-pressure oil is invisible and can cause serious injury. **ALWAYS** use cardboard or wood pieces to assist your inspection



WARNING

Be careful about exhaust gas.

1. Use the machine in a ventilated area.
2. Make sure the room is ventilated especially when using the machine indoor.

* Failure to observe this precaution can result personal injuries.



WARNING

Do not touch with your bare hands.

1. Following by rapid raise of the oil temperature, the temperature of the machine goes up while and after the operation. **DO NOT** touch the machine with your bare hands.
2. The temperature of tools will also raise while or after the operating. **BE SURE** that you always wear protective tool while using tools.

* Failure to observe this warning could result getting burned.



WARNING

Before operating the tool, be sure to wear personal protective equipment such as follows:

1. **Helmet**
2. **Protective goggles**
3. **Protective boots**
4. **Safety gloves**
5. **Ear protection**
6. **Dust mask**

* Failure to observe this precaution could result serious personally injuries.



 **DANGER**

KEEP fire AWAY

1. Keep fire away from the fuel filling port.
2. TURN OFF the engine when refilling fuel.

* Failure to observe this precaution can result fire, explosion and cause serious personally injuries.

 **WARNING**

Do not operate the tool if:

1. you are taking medication, feeling drowsy, unwell or tired.
2. you are under the influence of drugs or alcohol.
3. your hands, feet, lower back or other parts of your body hurt or are injured.

* Failure to observe this warning could result in serious injury or even death.

 **CAUTION**

When lending someone the tool

Make sure the safety instructions have been thoroughly read and fully understood by the person who is going to use the tool.

* Failure to observe this precaution can result serious personal injuries or damage the machines.



WARNING

Do not operate the tool on the slope

- 1. Do not operate the tool on the slope.**
- 2. When operating the tool on uneven ground, make sure to place stopper on the wheels to prevent moving.**

* Failure to observe this precaution can result serious personal injuries or damage the machines.

Hydraulic systems and their components are in accordance with ISO 4413:2010, Hydraulic fluid power General rules and safety requirements for systems and their components.

INTRODUCTION

1. This hydraulic power unit is a power source only designed to supply hydraulic oil for working the following handheld tools:
 - (1) Hydraulic Handheld Breakers: BH053, BH7E, BH112, BH163, BH18K, BH23K, BH20EV, BH23K28A, BH23K28AV, BH23K32EV
 - (2) Hydraulic Pile Drivers: KH240V, KH192
 - (3) Hydraulic Rock Drills: DH204, DH205
 - (4) Hydraulic Concrete Cutter: CH130, CH140
 - (5) Hydraulic Handheld Earth Drill: OH1, AY01H
 - (6) Hydraulic Water Pump: PH300

2. **DO NOT** operate the power unit in the following situations:
 - (1) Close by inflammable objects or objects which can catch fire easily. Especially when refueling gasoline.
 - (2) Use the power unit on slopes.
 - (3) Underground, or any places which are not well-ventilated.
 - (4) At high altitudes which exceeds 1,000 m
(*Ask Maruzen dealer if you intend to use the power units on high altitudes)
 - (5) Use the power unit in explosive environment.
 - (6) Use the power unit for purposes other than stated in this manual.

SPECIFICATIONS & DESCRIPTIONS

Overall Dimensions L591 x W480 x T 550 mm

Overall Weight 45 Kg

Working pressure range 7 – 10 MPa

Max. Pressure 11.7 MPa

Oil Flow 20.5L/min

Engine Honda GX200 Max. Output 4.3KW

CO2 value 757 g/kW-hr

Working temperature range -10°C ~ 40°C

Fuel Tank Capacity 3.1L

Hydraulic Reservoir Capacity 4L

Sound Power (2000/14/EC)

* Based on ISO 11148-3, implemented the noise measurement

-Measured Sound Power Level 98 Lwa =dB(A)

-Guaranteed Sound Power Level 99 Lwa =dB

Coupling 3/8 in couplers

Recommended Hydraulic Oil ISO VG32 or equivalent

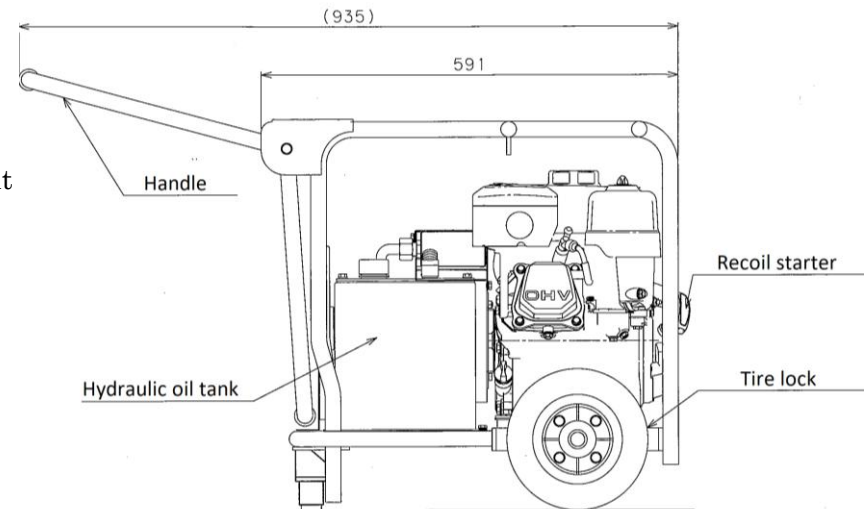
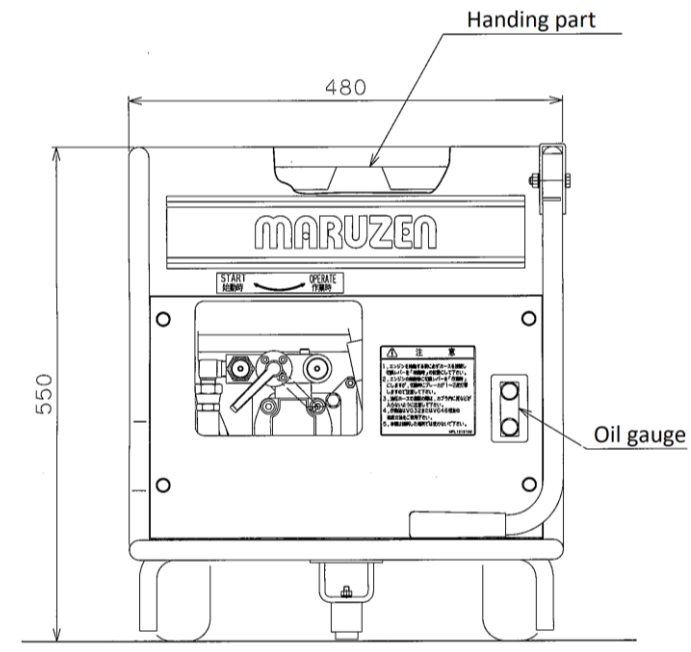

PRECAUTION LABELS AND POSITI

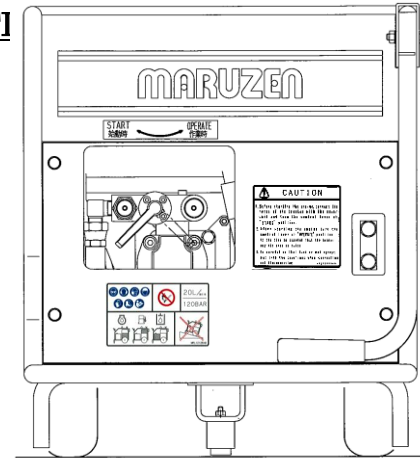
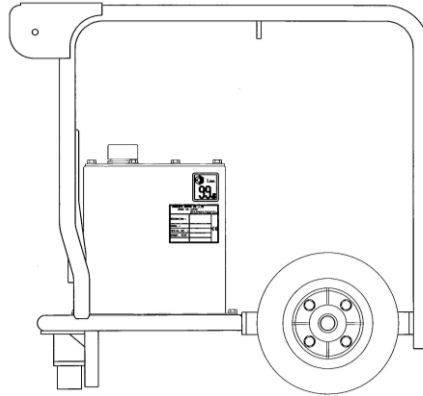
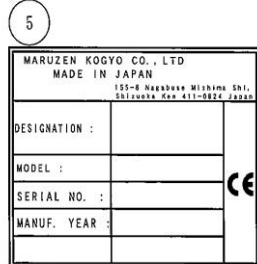

Precaution Labels warn you to pay extra attention for potential hazards. Ensure all decals are legible. Replace new one when they are needed.
Order your precaution labels from your nearest Maruzen dealer.

	Code	Description
①		E/G PL Label
②	MPL1Z125A	Label CF (CAUTION)
③	MPL1Z063A	Label BP (CAUTION)
④	MPL2Z007A	Sound Power Level Sticker (99)
⑤	MPL2Z002A	CE Sticker(English)

GUIDELINES

1. Always wear protective equipment such as helmet, goggles, boots, gloves, ear protection and dust mask.
2. Do not use this power unit on slops.
3. Make sure that dirt or dust does not get into hoses while connecting and disconnecting.
4. Make sure to lock couplers and check out whether there is damage when connecting with them.
5. Warm up the engine before using if the temperature is below 10°C
Working temperature range : -10°C ~ 40°C
6. Keep fire and flammable material away from working space.
7. Anything related to engine, such as adjustments, storage and etc., refer to Honda Engine owner's manual for more information.
8. Be cautious about not to damage the electric wirings, or getting wet by water.
9. Make sure whether the pressure resistance of the hose is appropriate. In case of sudden hydraulic hose breakage or hydraulic oil blow out of the hose. **STOP** the power unit **IMMEDIATELY**.
10. After disconnecting attachments (breakers, etc.) from the power unit, make sure all the couplers are capped to prevent dirt or dust getting inside.
11. When connecting or disconnecting hoses, a small amount of hydraulic oil might drip down. Make sure that surrounding area does not get dirty by oil. Refill the hydraulic oil if necessary.

12. Drain gasoline if you intend to store the power unit for more than 1 month. (Drain gasoline from the tank. To make sure all gasoline has been drained completely, run the engine until it automatically stops.)

13. When intend to use the power unit after a long term storage, make sure the gasoline tank is full-filled. If the tank is not full-filled, the air which remained inside fuel hose will disturb oil flow and cause it difficult to start the engine.

14. Hydraulic power units can be stored in 3 tiers under the following conditions:
 1. Must be stored on a flat space.
 2. Rubber feet must be put into the attachments on power unit.
(Refer to the drawing next page)
 3. A block must be put under the lowest power unit.
(Refer to the drawing next page)

OPERATION

1. Pre-starting Inspection:

- (1) Engine Oil:
Check the engine oil level by oil gauge. Refill engine oil when the oil is below the min. level.

Recommended engine oil:
SAE 10W-30 or equivalent.
Capacity: 0.6L

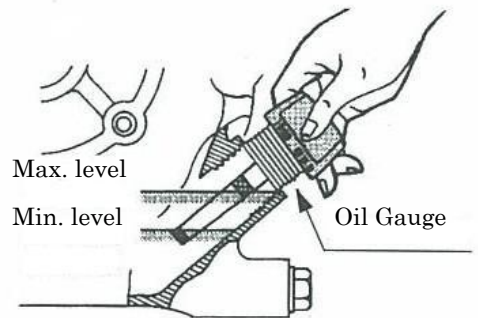

- (2) Hydraulic Oil:
Refill hydraulic oil when the oil level is below 1/2 of the oil indication window. Open the plug on the top of the oil tank, fill in hydraulic oil until the oil level reach to the middle of the indication window.

Recommended hydraulic oil: **ISO VG32** or equivalent.

Capacity: 4L

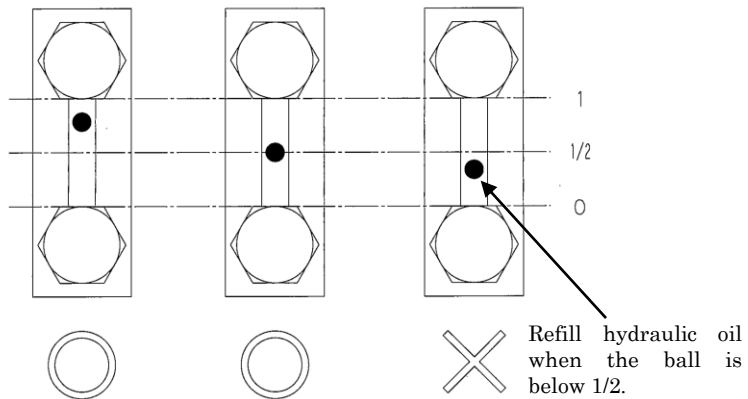

- (3) Fuel:
Refill gasoline into the fuel tank.
Capacity: 3.1L
Do not forget to close the cap.

* Wipe off spilled gasoline on the power unit.
Keep fire and flammable material away from working space.

- (4) Unlock the latch on breaker, insert a tool, and lock the latch.

2. Starting Engine:

- (1) Attach the power unit and the tool (breakers and etc.) with connection hoses before starting engine.
Make sure to lock couplers.
DO NOT start engine without connecting to tool with hoses.
MAKE SURE control lever is set at "START" position.

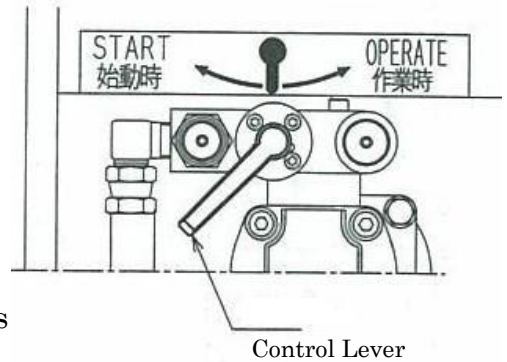

- (2) Start operation

- ① Open the fuel cock.

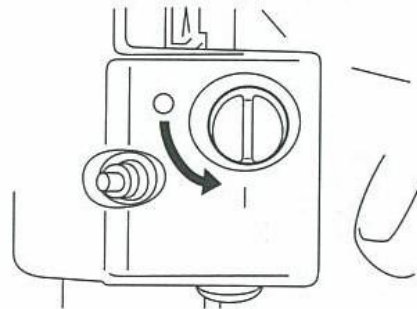

- ② Turn the switch to "ON"

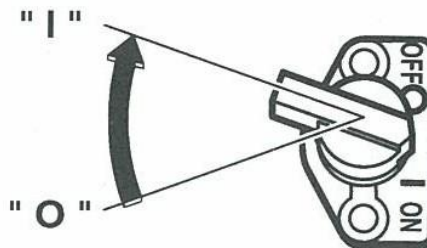

- ③ Turn the speed control lever from low speed (L) toward to high speed (H) and stop at 1/3 closer to (H) position.

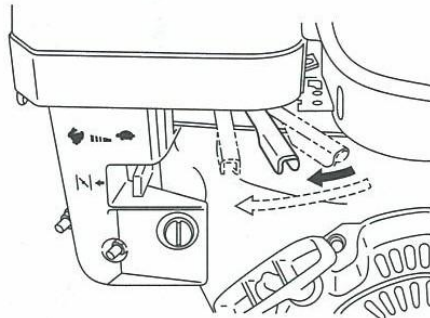

- ④ Close the choke lever.

When to open the choke lever:

- When the temperature is low or when the engine is cold, close the choke lever.
- When the temperature is warm or when starting the engine right after stopping, fully or partially open the choke lever.

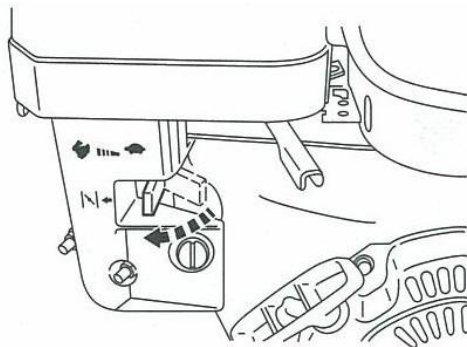

- ⑤ Pull start rope gradually. **DO NOT** pull the starting rope quickly. After the rope being fully pulled, **DO NOT** release it from your hand. Hold the starting rope until it returns to its original position.

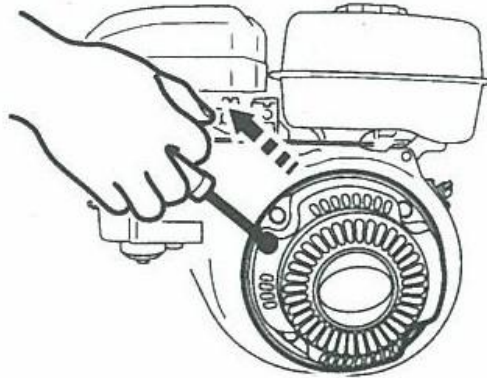

- ⑥ After the engine being started, open the choke lever.
- Open the choke lever gradually according to the engine's condition. Eventually, the choke lever should be fully opened.
 - When the weather is cold, engine might stop if you turn the choke lever too rapidly.

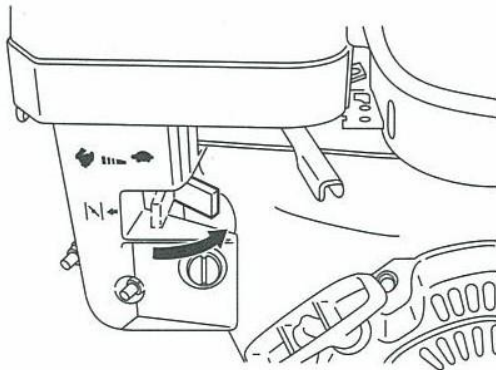

3. Operation:

(1) Turn the throttle to high speed (H)

(2) Turn the control lever to the “OPERATE” position.
(Refer to the drawing on the right)

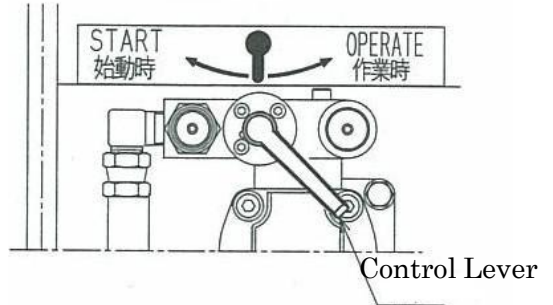

(3) Read through all operating manuals of tools which you intend to use with this power unit.

(4) When stopping the operation of the tool (breakers and etc) ALWAYS turn the engine throttle to the Low Speed (L) side. This can save energy and reduce the noise level.

4. Stoppage:

(1) Turn the speed control lever to Low Speed (L) side and run the machine for 1 to 2 minutes.

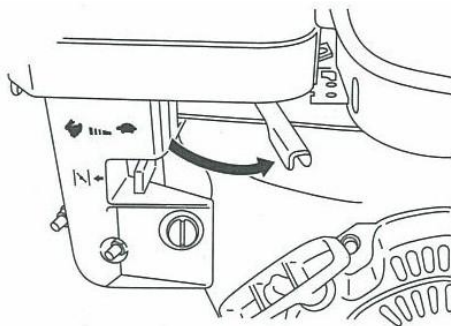

- (2) Turn the switch to “O” Off side.
IMPORTANT When emergency happened and need to stop the power unit immediately, turn off this switch.

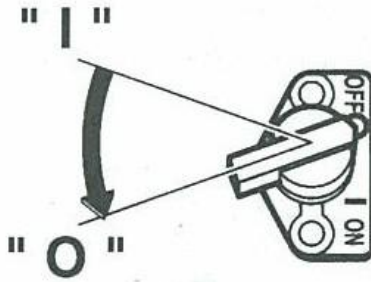

- (3) Turn off the fuel cock.

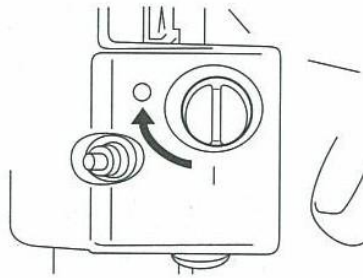

- (4) Detach connection hoses from tool (breakers and etc).
Connect couplers on the hoses together.

⚠ CAUTION

The temperature of the machine goes high while being operated. Always wear gloves when operating the tools (breakers and etc,) and be attentive for the heat on the tools (breakers and etc), hoses and power unit.

MAINTANANCE

I. Daily Inspections

- (1) Make sure the power unit is OFF when inspecting to avoid unexpected movement.
- (2) Check the engine oil level each time by oil gauge before starting the engine.
- (3) Make sure hydraulic oil is above the middle line on the indicator window. Refill hydraulic oil if necessary.
(Recommended Hydraulic Oil: ISO VG32 or equivalent)
- (4) Clean the element of the air cleaner in the engine.
- (5) Make sure there is no oil leakage from the pump and hoses. Tighten up the hose joints and bolts if necessary.
- (6) Start the engine, run at low speed (Idling) and make sure there is no abnormal sound and movement.

*For further information, ask Maruzen dealer.

II. Periodically Inspections

For the purpose of keeping the power unit in a good condition, make sure the following maintenance are done periodically.

Ask your dealer for the periodical inspections and replacement parts.

Item	Operating Hours		
	50H	100H	200H
Change engine oil	* ○		
Clean the air cleaner	○		
Clean the strainer			○
Clean the spark plug	○		
Change hydraulic oil		○	
Replace return filter			○
Clean the radiator		○	
Clean the suction filter			○
Clean the hydraulic oil reservoir			○

* The first replacement is 20 hours

1. Make sure to always wear protective equipment when refueling gasoline and oil, and replacing parts.
2. Make sure to work after stop working and temperature drops enough.
3. Do not close fire such as cigarette when handling gasoline.
4. Drain hydraulic oil from the drain plug at the bottom of the oil tank.
Replace hydraulic oil when the color of hydraulic oil changed to yellow to brown or when it smells burning. Always use the same type of hydraulic oil.
5. Suction filter should be cleaned by non-lead gasoline.
6. Clean oil cooler.
7. Inspect the hoses which connected to breaker thoroughly.
Replace a new one if there are scratches, damages which may cause oil leak.

TOOL DISPOSAL

- To dispose of the machinery, shall be performed in accordance with the national, or local laws, ordinances, rules, and standards.
- Do not disposal with fuel left in the power unit.
Make sure to run out gasoline by working before disposal.
- Dispose hydraulic oil of according to the oil manufacturer's instructions.

TROUBLE SHOOTING

Symptoms	Causes	Countermeasures
Engine does not start	1. No fuel or not enough fuel in the tank.	1. Refill the fuel tank
	2. Air left inside fuel hoses which causes the fuel can't reach to carburetor (possible causes: lack of gas or after a long storage)	2. Refill the fuel tank full or remove the fuel cock to remove the air
	3. Trouble of ignition plug	3. Clean or replace
	4. Clog of carburetor	4. Disassemble and clean the carburetor
	5. Fuel cock is closed	5. Open the fuel cock
	6. Overflow of fuel by overusing chock	6. Close the fuel cock the pull the starter for several times.
	7. Trouble of ignition system	7. Clean and maintain the ignition system*
	8. Clog of fuel filter	8. Clean the fuel filter
	9. Stop Switch is on "O" (OFF) position	9. Turn the Stop Switch to "I" (ON) position
	10. Damage of Stop Switch or wires damage or coming off	10. Inspecting or replace new stop switch, wires if necessary. *
	11. Clog of air cleaner	11. Clean the air cleaner
It is difficult to pull start rope (too heavy)	1. Hoses are not attached properly	1. Attach all the hoses and fittings properly
	2. Burning of cylinder due to lack of engine oil	2. Disassemble and maintain cylinder block*
	3. Damage of couplers	3. Inspection of couplers, replace new ones if necessary.

	4. The control lever is not on “START” position	4. Turn the control lever to “START” position
Engine rotation (rpm) does not raise up	1. Chock does not return to the original position	1. Turn the chock to its original position
	2. Lack of fuel	2. Refill the fuel
	3. Clog of fuel filter	3. Clean the fuel filter
	4. Clog of air cleaner	4. Clean the air cleaner
Attachment tools are not function, or weak performance	1. Lack of hydraulic oil	1. Refill the hydraulic oil
	2. Insufficiency of the hydraulic oil	2. Change hydraulic oil
	3. Decrease of relief valve pressure	3. Adjust pressure of relief valve pressure *
	4. Inefficiency of pump due to the wear of it	4. Replace a new pump *
	5. Damage of couplers	5. Replace new couplers
	6. The Control Lever is on “START” position	6. Turn the control Lever to “OPERATE” Position
Oil temperature is abnormally high (exceed 80°C)	1. Clog of radiator	1. Clean the radiator
	2. Clog of fan	2. Clean the fan
Oil leakage from hoses and couplers	1. Hoses, couplers attachments get loosen	1. Tighten the attachments
	2. Damage of hoses	2. Replace new ones
Engine does not stop even when the STOP SWITCH has been turned to “OFF” position	1. Switch wire, circuits break, loose connection	1. Inspection and repair *
The smell of gasoline from power unit	1. Fuel leakage from hoses	1. Inspection, Replace new hoses
	2. Fuel leakage from Cock	2. Inspection, Replace new cock

For items with *, ask Maruzen dealers for service and maintenance

EXPLODED VIEW (I) MODEL UH070

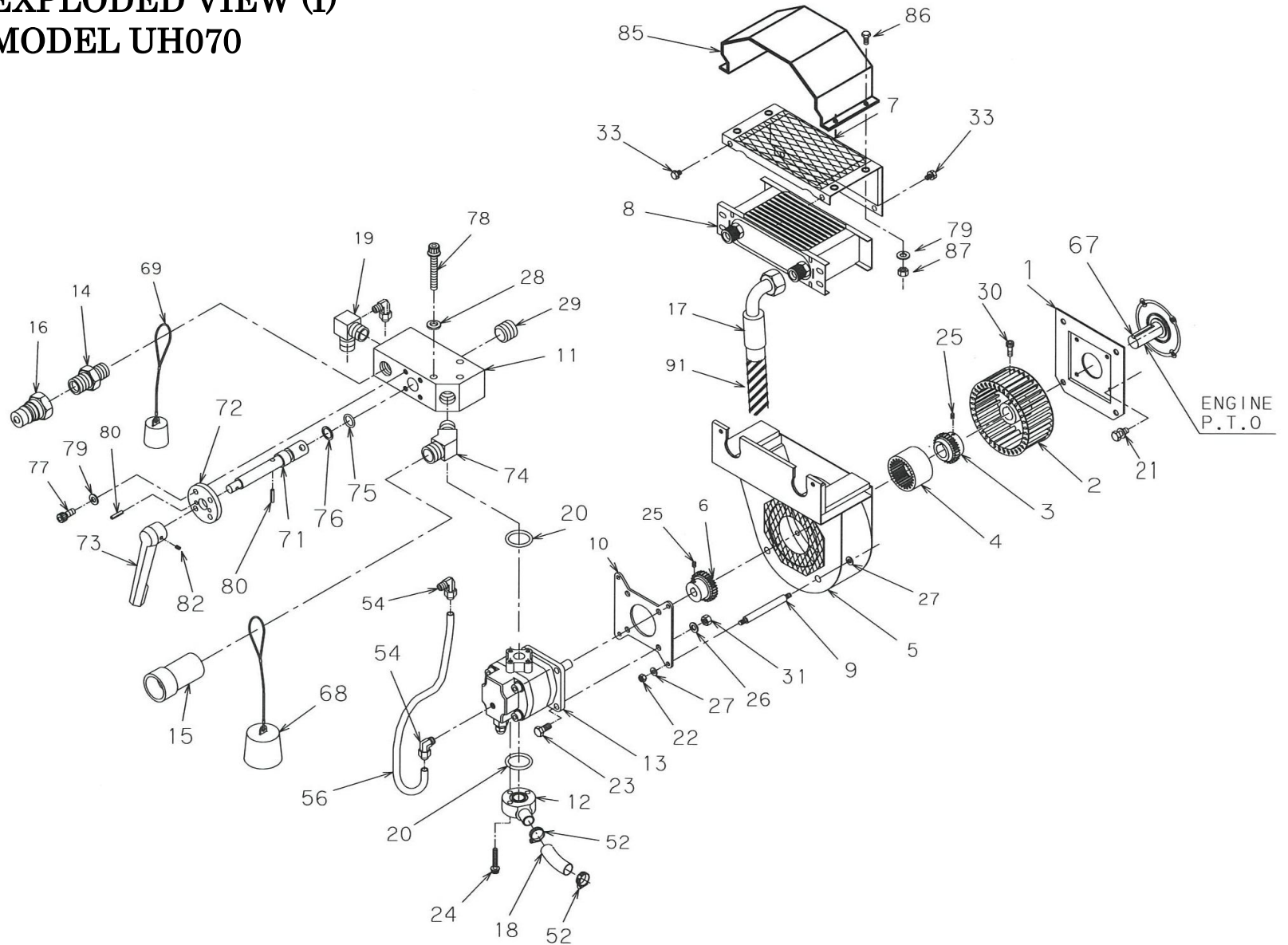

EXPLODED VIEW (II) MODEL UH070

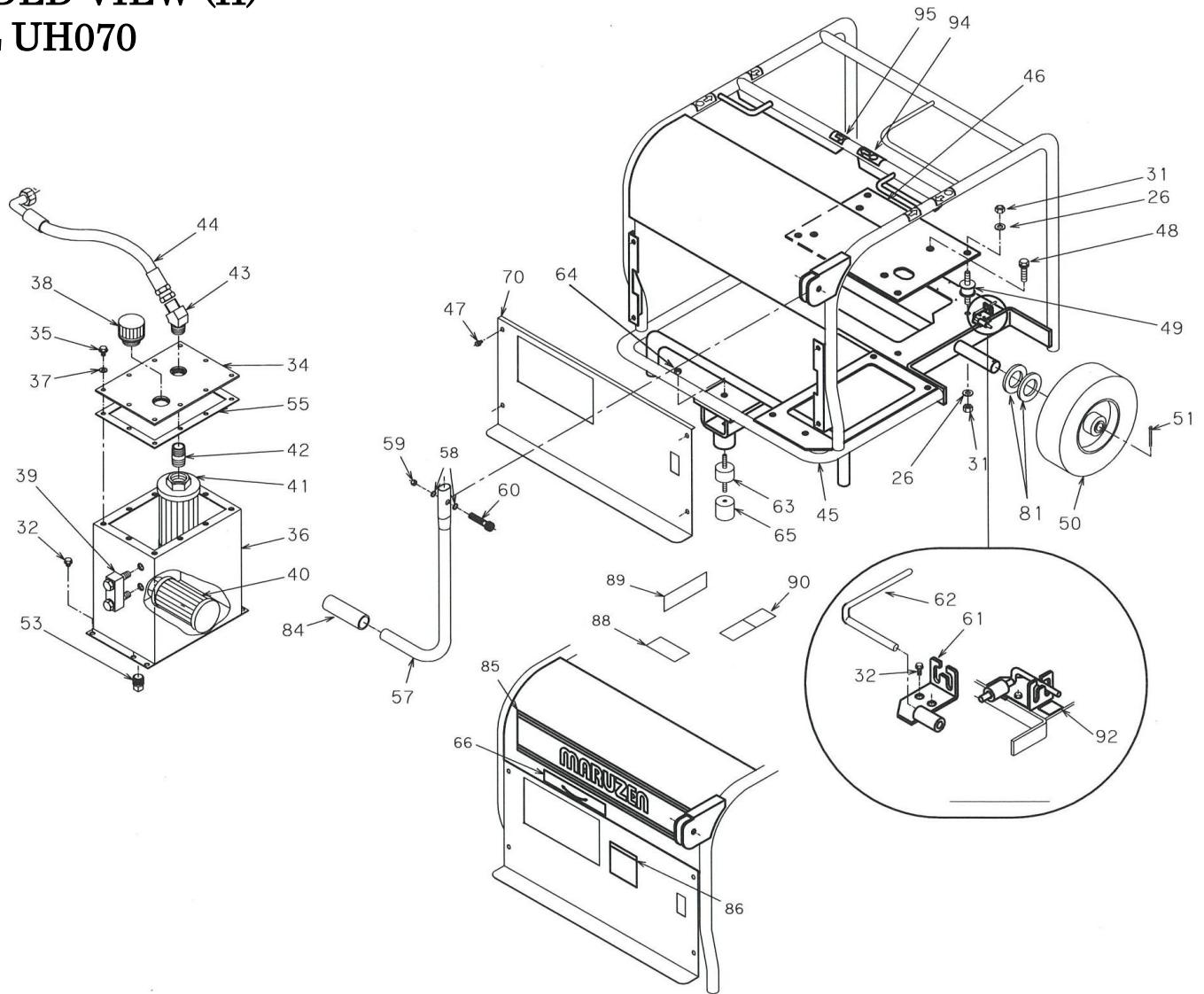

PARTS LIST

MODEL UH070

No.	Code	Description	Q'ty	No.	Code	Description	Q'ty
1	MU02E019A	Mounting Plate(A)	1	24	BH-6x35(2P)	Bolt	3
2	CAB050050020BY (H)	FAN(T)	1	25	SH-4x8	Set screw (Chromate)	2
3	MU08Z052A	Coupling(E)	1	26	WS-8	Washer	12
4	MU08Z054A	HUB	1	27	WS-6	Washer	8
5	MU08Z064A	FAN CASE(N) ASSY	1	28	MU02Z092A	Washer	3
6	MU08Z053A	Coupling(P)	1	29	BPH1-PT3/8	Plug	1
7	MU08Z051A	Radiator cover ASSY	1	30	BH-4x8	Bolt (Chromate)	1
8	MU08Z007A	Radiator	1	31	N1-8	Nut	12
9	MU02E008B	Draw bolt	4	32	B-6x15(2P)	Bolt	6
10	MU11Y001A	Pump flange for overseas	1	33	B-6x10(2P)	Bolt	4
11	MU08Z018A	Valve body(L)	1	34	MU08Z006A	Lid	1
12	MU04Z006A	Suction flange	1	35	BG-6x15	Bolt	10
13	403-40099	Pump	1	36	MU08Y002A	Tank	1
14	AJ-2083-06	Adaptor	1	37	1240-404	φ 6 Washer	10
15				38	BM-3/4	Tank cap	1
16		Coupler	1	39	KLA-40A-C	Oil Gauge M10 red (M10 red float)	1
17	01126 · 8—52--	Law pressure hose	1	40	CT-04W	Suction filter	1
18	MU08Z019A	Suction hose	1	41	RC-04-30-15	Return filter	1
19	MU08Z009A	Elbow	1	42	LJ-04BN	Barrel nipple	1
20	OP-22	O-ring	2	43	AJ-1036-08	Elbow	1
21	BH-8x20(2P)	Bolt	4	44	01126 · 8—31--	Low pressure hose	1
22	N1-6	Nut	4	45	MU17X001A	Flame	1
23	B-8x25	Bolt	4	46	MU08Z044A	Engine Base	1

PARTS LIST

MODEL UH070

No.	Code	Description	Q'ty	No.	Code	Description	Q'ty
47	B-8x20(3P)	Bolt	4	74	AJ-2097-06	Adaptor	
48	B-8x35(3P)	Bolt	4	75	OP-10(1A)	O-ring	1
49	KA-30	Anti-vibration rubber	4	76	OBP-10A	Back up ring	1
50	G-200B	Tire	2	77	BH-5x15	Bolt	4
51	PS-3.2x30	Pin	2	78	BH-6x45(2P)	Bolt	3
52	SS-8	Hose band	2	79	WS-5	Washer	4
53	BPQ-PT3/8	Plug	1	80	PR-4x14	Pin	3
54	L4N8x6-PT1/4	Elbow	2	81	WP-20	Washer	4
55	MU08Z005A	Tank packing	1	82	SH-5x6 (Togarisaki)	Set screw	1
56	N5-4x6-0.250 KURO	Tube	1	83	-	-	-
57	MU17Z005A	Handle	1	84	C-57	Line grip	1
58	WP-8	Washer	3	85	MU08Y113A	Radiator Cover EX	1
59	NN1-8	Nylon nut	1	86	B-5x12	Bolt	4
60	BH-8x40	Bolt	1	87	N1-5	Nut	4
61	MU17Z016A	Guided stay	1	88	-	-	-
62	MU17Z017A	Lever	1	89	-	-	-
63	KA-25	Anti-vibration rubber	1	90	-	-	-
64	NN-6	Nut	1	91	KS-15B L=250mm	Spiral tube	1
65	MU08Z058A	Front leg	1	92	MU17Z024A	Tire Stopper Label (ENG)	1
66				93	-	-	-
67	90741-883-810	Key	1	94	MU17Z014A	Hook Position Label (R)	3
68				95	MU17Z015A	Hook Position Label (L)	3
69							
70	MU17Y002A	Front cover	1				
71	MU08Z015B	Rotary(L)	1				
72	MU08Z017A	Plate(L)	1				
73	MU08Z030A	Fixed lever	1				

EU Declaration of Conformity (DoC)

We

Company name:	MARUZEN KOGYO CO., LTD
Address:	155-8 Nagabuse, Mishima-shi Shizuoka 411-0824, Japan

declare that the DoC is issued under our sole responsibility and belongs to the following product:

Apparatus model/Product:	Hydraulic Power Unit
Type/Model:	UH070
Serial number:	All

Object of the declaration (identification of apparatus allowing traceability; it may include a colour image of sufficient clarity where necessary for the identification of the apparatus):

(Identification of the apparatus) The UH-070 is a hydraulic power unit equipped with a gasoline engine and hydraulic pump. It is mainly used in connection with hand tools that are driven by hydraulic pressure. The unit has tires and can be pulled to move it.

The object of the declaration described above is in conformity with the following relevant Union harmonisation legislation:

Machinery Directive 2006/42/EC	Outdoor Noise Directive: 2000/14/EC
--------------------------------	-------------------------------------

The following standards, technical specifications and these reference standards have been applied:

EN ISO 12100:2010	EN ISO 3744:1995
EN ISO 4413:2010	

The person authorized to compile the technical file (documentation)

Company name or Name:	OSTLINK ZIPANG
Address:	Karolinengasse 19, 23, 1040, Wien AUSTRIA

Additional information

Sound Declaration

Measured sound power level: 99 dBA, Generated sound power level: 100dBA

Signed for and on behalf of:

Shizuoka

2023/07/13



Place of issue

Date of issue

Yukio Suwabe, President

ORIGINAL